



Shaft Hedge Clipper

Operator's Manual

MODELS:

SHC-1700 - Type 1 - S/N 001001 & Up

SHC-1700 - Type 1E - S/N 00504768 & Up

SHC-2100 - Type 1 - S/N 001001 & Up

SHC-2100 - Type 1E - S/N 00506456 & Up

SHC-2400 - Type 1 - S/N 001001 & Up

SHC-2400 - Type 1E - S/N 00501001 & Up

HCA-2400 - Type 1E - S/N 00501001 & Up



WARNING



The engine exhaust from this product contains chemicals known to the State of California to cause cancer, birth defects or other reproductive harm.

WARNING DANGER

Read rules for safe operation and instructions carefully. ECHO provides an Operator's Manual and a Safety Manual. Both must be read and understood for proper and safe operation. Failure to do so could result in serious injury.

INTRODUCTION

Welcome to the ECHO family. This ECHO product was designed and manufactured to provide long life and on-the-job dependability. Read and understand this manual and the SAFETY MANUAL you found in the same package. You will find both easy to use and full of helpful operating tips and SAFETY messages.

WARNING DANGER

Read rules for safe operation and instructions carefully. ECHO provides an Operator's Manual and a Safety Manual. Both must be read and understood for proper and safe operation.

THE OPERATORS MANUAL --

contains specifications and information for operation, starting, stopping, maintenance, storage and assembly specific to this product.

THE SAFETY MANUAL --

explains possible hazards involved with the use of Hedge Clippers and what measures you should take to make their use safer.

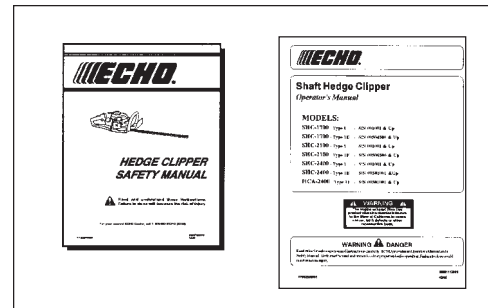

TABLE OF CONTENTS

Introduction	2	- Starting Cold Engine	20
- The Operator's Manual	2	- Starting Warm Engine	21
- The Safety manual	2	- Stopping Engine	22
Manual Safety Symbols and Important Information	3	Maintenance	23
Safety	3	- Skill Levels	23
- General Description	3	- Maintenance Intervals	24
- Decals	4	- Air Filter	25
- International Symbols	5	- Fuel Filter	25
- Equipment	5	- Spark Plug	26
- Fuel	6	- Cooling System Cleaning	26
- Personal Condition and Safety Equipment	6	- Exhaust System	27
- Safe Operation	8	- Carburetor Adjustment Emission	28
- Extended Operation/Extreme Conditions	10	- Carburetor Adjustment Non Emission	29
Description	11	- Lubrication	30
- Contents	11	- Sharpening Blades	31
- Emission Control	11	Troubleshooting	32
Specifications	14	Storage	33
- Models SHC-1700, 2100, 2400, HCA-2400	14	Servicing Information	36
Assembly	15	- Parts	36
- Gear Housing Assembly / Drive Shaft	15	- Service	36
- Power Head / Drive Shaft	15	- ECHO Consumer Product Support	36
- Throttle Cable and Ignition Leads	16	- Warranty Card	36
Pre-Operation	17	- Additional or Replacement Manuals	36
- Fuel	18	- Manual Ordering Instructions	36
- Equipment Check	18		
- Determine Operation Area	19		
Operation	19		

Specifications, descriptions and illustrative material in this literature are as accurate as known at the time of publication, but are subject to change without notice. Illustrations may include optional equipment and accessories, and may not include all standard equipment.

MANUAL SAFETY SYMBOLS AND IMPORTANT INFORMATION

Throughout this manual and on the product itself, you will find safety alerts and helpful, information messages preceded by symbols or key words. The following is an explanation of those symbols and key words and what they mean to you.



This symbol accompanied by the words **WARNING** and **DANGER** calls attention to an act or condition that can lead to serious personal injury to operator and bystanders.



The circle with the slash symbol means whatever is shown within the circle is prohibited.



IMPORTANT The enclosed message provides information necessary for the protection of the unit.

NOTE This enclosed message provides tips for use, care and maintenance of the unit.

SAFETY

GENERAL DESCRIPTION

IMPORTANT

See Description and Specification sections for full description and illustration of model variation in power head, and handle type.

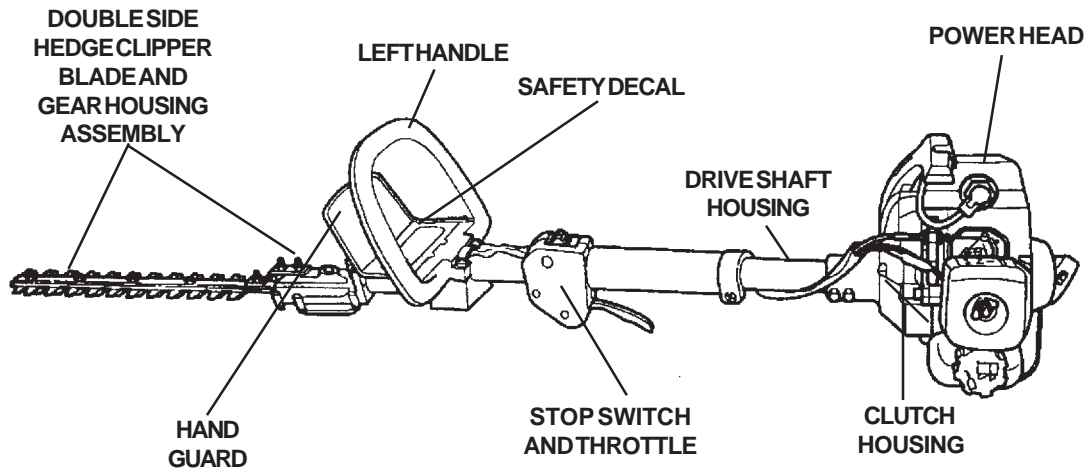

SHC-1700 SHOWN

DECALS, WARNING/INFORMATIONAL

Locate these safety decals on your unit. The complete unit illustration found in the "DESCRIPTION" section, will help you locate them. Make sure the decals are legible and that you understand and follow the instructions on them. If a decal cannot be read, a new one can be ordered from your ECHO dealer. See PARTS ORDERING instructions for specific information.

HCA/SHC-2400 DRIVE SHAFT



WARNING ⚠ DANGER



This unit is not designed to insulate against hazards associated with the contact of wires carrying electrical current.

To avoid possible injury/death due to electrical shock or other hazards, **DO NOT** operate unit if any wires (power, telephone, cable, etc.) are closer than 15 feet (4.5 meters) minimum distance, to any part of the unit or operator.

P/N 890178-54331

HCA-2400 DRIVESHAFT



WARNING ⚠ DANGER



• This unit can be dangerous if used improperly. • Falling objects and/or blade contact can cause serious injury to operator, helpers and bystanders. • Keep helpers and bystanders at least 50 feet (15m) clear of operating area. • To reduce injury risk, **READ AND UNDERSTAND** the Operators Manual, replacement copies are available through any ECHO Dealer. • Wear Protective Clothing (head, hearing and eye protection meeting ANSI standards) specified in the Operators Manual. • **NEVER** operate unit if ignition interlock does not work. • **NEVER** intentionally bypass the interlock system. • **STOP** engine before making repairs or blade angle adjustments. • **ALWAYS** use the adjustment handle when adjusting blade angle. • Keep hands away from blade.

SHC-2400 DRIVESHAFT



WARNING ⚠ DANGER



• This unit can be dangerous if used improperly. • Falling objects and/or blade contact can cause serious injury to operator, helpers and bystanders. • Keep helpers and bystanders at least 50 feet (15m) clear of operating area. • To reduce injury risk, **READ AND UNDERSTAND** the Operator's Manual, replacement copies are available through any ECHO Dealer. • Wear Protective Clothing (head, hearing and eye protection meeting ANSI standards) specified in the Operator's Manual. • **STOP** engine before making repairs or blade adjustments • Keep hand away from blade.

P/N 89016021560

SHC-1700, 2100 HAND GUARD



WARNING ⚠ DANGER



This unit is not designed to insulate against hazards associated with the contact of wires carrying electrical current. To avoid possible injury/death due to electrical shock or other hazards, **DO NOT** operate unit if any wires (power, telephone, cable, etc.) are closer than 15 feet (4.5 meters) minimum distance, to any part of the unit or operator. • This unit can be dangerous if used improperly. • Falling objects and/or blade contact can cause serious injury to operator, helpers and bystanders. • Keep helpers and bystanders at least 50 feet (15m) clear of operating area.

• To reduce injury risk, **READ AND UNDERSTAND** the Operator's Manual. Replacement copies are available through any ECHO Dealer.













• Wear Protective Clothing (head, hearing and eye protection meeting ANSI standards) specified in the Operator's Manual. • **STOP** engine before making repairs or blade adjustments. • Keep hand away from blade.



INTERNATIONAL SYMBOLS

Symbol form/shape	Symbol description/application	Symbol form/shape	Symbol description/application
	Read and understand Operator's Manual.		Fuel and oil mixture
	Wear eyes, ears and head protection		Finger Severing
			Wear hand protection. Use two handed.
	Hot Surface		DO NOT smoke near fuel.
	Safety/Alert		DO NOT allow flames or sparks near fuel.
	Avoid all power lines. This unit is not insulated against electrical current.		Do not operate closer than 15 M (50 ft.) from electrical hazards.

Symbol form/shape	Symbol description/application	Symbol form/shape	Symbol description/application
	Keep bystanders at least 15 meters (50 feet) away.		Plan retreat path from falling objects.
	Emergency stop		Wear slip resistant foot wear.
	Engine choke control.		Ignition ON/OFF
	Primer bulb		Carburetor adjustment - High speed mixture
	Carburetor adjustment - Low speed mixture		Carburetor adjustment - Idle speed

EQUIPMENT

Before operation a complete check of the unit must be performed;

- Check unit for loose/missing nuts, bolts and screws. Tighten and/or replace as needed.
- Inspect fuel lines, tank and area around carburetor for fuel leaks. DO NOT operate unit if leaks are found.
- Inspect hand guard for damage. Replace if damaged or missing.
- Check that the blade assembly is firmly attached and in safe operating condition. Dull, loose or damaged blades should not be used.
- Check that front loop handle and shoulder strap/ or shoulder/ waist harness are adjusted for safe, comfortable operation.
- Tighten the blade angle adjustment lever before operating the HCA-2400.

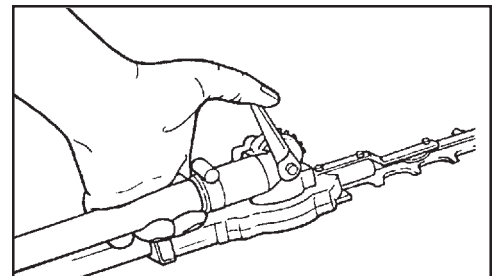
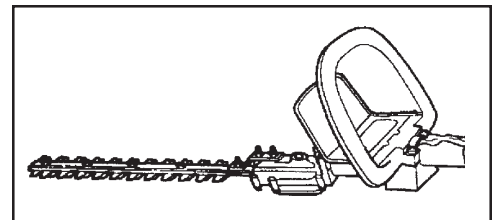
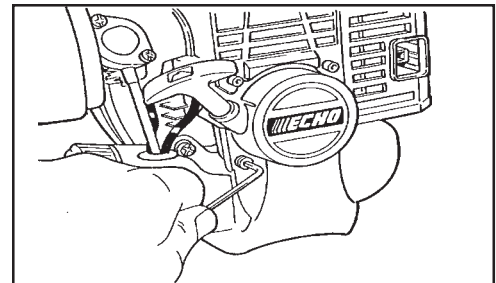

IMPORTANT

Always store and transport Shaft Hedge Clipper in a stable, horizontal position. Support gear case and cutting blades to prevent excessive flexing, which may cause damage to the cutting attachment.

FUEL

WARNING DANGER

Fuel is **VERY** flammable. Use extreme care when mixing, storing or handling or serious personal injury may result.

- Use an approved fuel container.
- DO NOT smoke near fuel.
- DO NOT allow flames or sparks near fuel.
- Fuel tanks/cans may be under pressure. Always loosen fuel caps slowly allowing pressure to equalize.
- NEVER refuel a unit when the engine is HOT!
- NEVER refuel a unit with the engine running.
- DO NOT fill fuel tanks indoors. ALWAYS fill fuel tanks outdoors over bare ground.
- Securely tighten fuel cap after refueling.
- Inspect for fuel leakage. If fuel leakage is found, do not start or operate unit until leakage is repaired.



After Refueling;

- Wipe any spilled fuel from the unit.
- Move at least 3M (10 ft.) from refueling location before starting.

After Use;

- DO NOT store a unit with fuel in its tank. Leaks can occur. Return unused fuel to an approved fuel storage container.



PERSONAL CONDITION AND SAFETY EQUIPMENT

WARNING DANGER

Hedge Clipper users risk injury to themselves and others if the shaft hedge clipper is used improperly and or safety precautions are not followed. Proper clothing and safety gear must be worn when operating a shaft hedge clipper.

Physical Condition

Your judgment and physical dexterity may not be good:

- if you are tired or sick,
- if you are taking medication,
- if you have taken alcohol or drugs.

Operate unit only if you are physically and mentally well.



Eye Protection

Wear eye protection meeting ANSI Z87.1 of CE requirements whenever you operate the unit.

Face and Head Protection

When trimming overhead, wear head protection meeting ANSI Z89.1 or CE requirements with a full face shield. Head protection with full face shield will help protect you from falling debris.

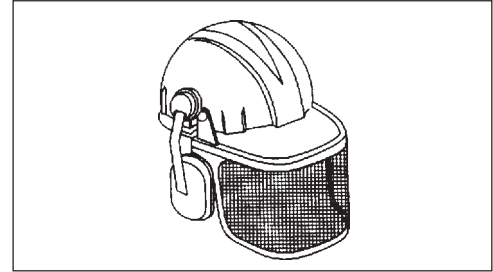

Hand Protection

Wear no-slip, heavy duty work gloves to improve your grip on the Shaft Hedge Clipper handles. Gloves also reduce the transmission of machine vibration to your hands.

Hearing Protection

ECHO recommends wearing hearing protection whenever unit is used.

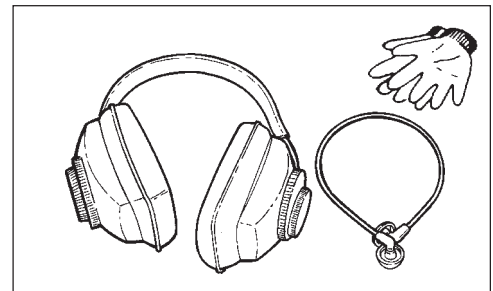

Proper Clothing

Wear snug fitting, durable clothing;

- Pants should have long legs, shirts with long sleeves.
- DONOT WEAR SHORTS,
- DONOT WEAR TIES, SCARVES, JEWELRY.

Wear sturdy work shoes with non-skid soles;

- DONOT WEAR OPEN TOED SHOES,
- DONOT OPERATE UNIT BAREFOOTED.



Hot Humid Weather

Heavy protective clothing can increase operator fatigue which may lead to heat stroke. Schedule heavy work for early morning or late afternoon hours when temperatures are cooler.

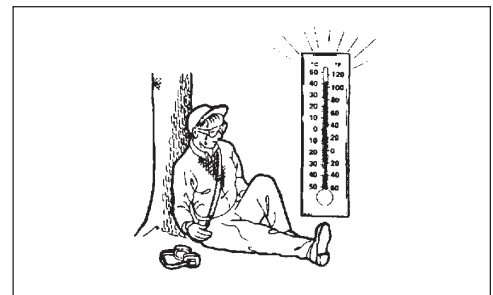

SAFE OPERATION

Determine Operation Area

- Provide all operators of this equipment with the Operator's Manuals and instructions for safe operation.
- Review the area to be trimmed. Look for hazards that could contribute to unsafe conditions. DO NOT operate unit if any wires (power, telephone, cable, etc.) are closer than 4.5 M (15 ft.) to any part of the operator or unit.
- Spectators and fellow workers must be warned, and children and animals prevented from coming nearer than 15 M (50 ft.) while the Hedge Clipper is in use.

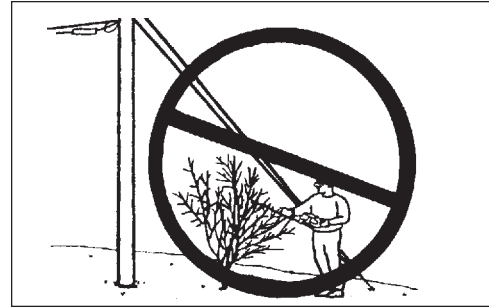

Operation

Use Proper Clothing & Equipment

- Before starting the unit, equip yourself and any other person working within the 15 M (50 ft.) Safety Zone with the required Protective Equipment and clothing.

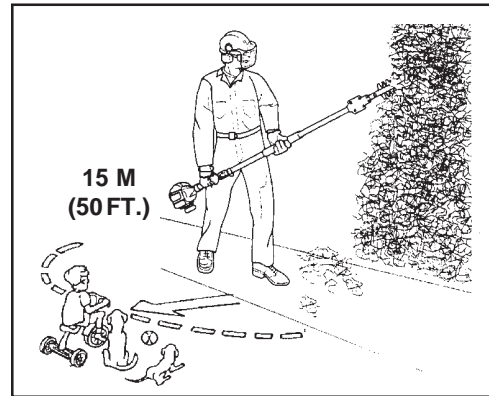

WARNING **DANGER**

Do not operate this product indoors or in inadequately ventilated areas. Engine exhaust contains poisonous emissions and can cause serious injury or death.

Avoid Hot Surfaces

- During operation, the complete unit, especially the drive shaft housing, power head, muffler area and gear box may become very hot, too hot to touch. Avoid contact during and immediately after operation.

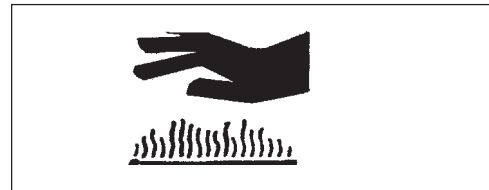

Keep A Firm Grip

- Hold the front and rear handles with both hands with thumbs and fingers encircling the handles

Keep A Solid Stance

- Maintain footing and balance at all times. Do not stand on slippery, uneven or unstable surfaces. Do not work in odd positions or on ladders. Do not over reach.



Operation (HCA)

- Never adjust blade angle of HCA while standing.
- Only adjust cutting angle with HCA resting flat on the ground, with the engine stop switch in the "STOP" position.
- Adjust cutting angle by moving locking lever (A) up. Depress blade indexing lever (B) and change blade angle with rear cutter assembly handle. Release indexing lever (B) into notch. Move locking lever (A) down to completely engage internal gears.

IMPORTANT

Lever (A) does not secure gearbox angle setting. Moving lever in the down position reduces internal play in the gear box. Do not over tighten castle nut (C) to insure gear box angle setting tightness because damage to internal gears will occur. If the lever is loose or very tight adjust nut (C) for snug 90° movement.

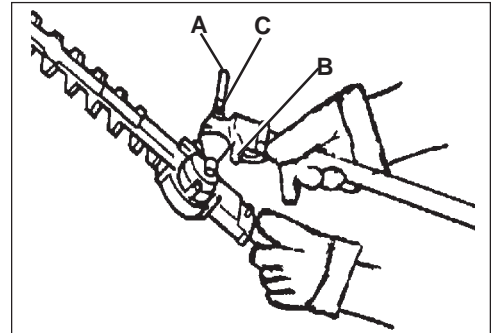

EXTENDED OPERATION/EXTREME CONDITIONS

Vibration and Cold

It is believed that a condition called Raynaud's Phenomenon, which affects the fingers of certain individuals may be brought about by exposure to vibration and cold. Exposure to vibration and cold may cause tingling and burning sensations followed by loss of color and numbness in the fingers. The following precautions are strongly recommended because the minimum exposure which might trigger the ailment is unknown.

- Keep your body warm, especially the head, neck, feet, ankles, hands and wrists.
- Maintain good blood circulation by performing vigorous arm exercises during frequent work breaks and also by not smoking.
- Limit the hours of operation. Try to fill each day with jobs where operating the trimmer or other hand-held power equipment is not required.
- If you experience discomfort, redness and swelling of the fingers followed by whitening and loss of feeling, consult your physician before further exposing yourself to cold and vibration.

Repetitive Stress Injuries

It is believed that overusing the muscles and tendons of the fingers, hands, arms and shoulders may cause soreness, swelling, numbness, weakness and extreme pain in those areas. Certain repetitive hand activities may put you at a high risk for developing a Repetitive Stress Injury (RSI). An extreme RSI condition is Carpal Tunnel Syndrome (CTS), which could occur when your wrist swells and squeezes a vital nerve that runs through the area. Some believe that prolonged exposure to vibration may contribute to CTS. CTS can cause severe pain for months or even years.

To reduce the risk of RSI/CTS, do the following:

- Avoid using your wrist in a bent, extended or twisted position. Instead try to maintain a straight wrist position. Also, when grasping, use your whole hand, not just the thumb and index finger.
- Take periodic breaks to minimize repetition and rest your hands.
- Reduce the speed and force with which you do the repetitive movement.
- Do exercises to strengthen the hand and arm muscles.
- Immediately stop using all power equipment and consult a doctor if you feel tingling, numbness or pain in the fingers, hands, wrists or arms. The sooner RSI/CTS is diagnosed, the more likely permanent nerve and muscle damage can be prevented.

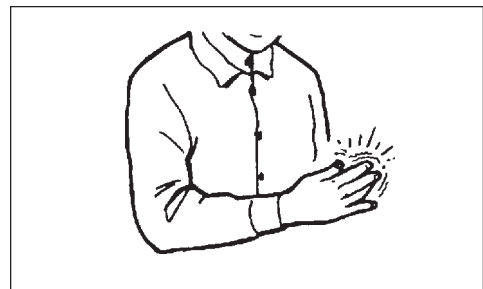
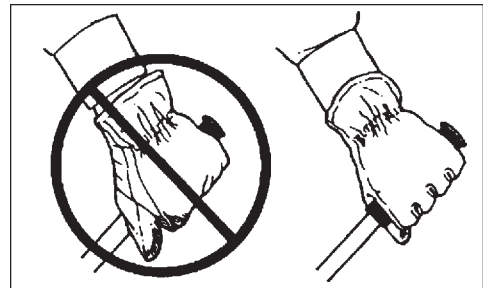
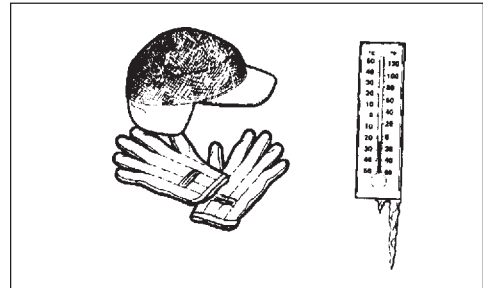

DESCRIPTION

The ECHO product you have purchased has been factory pre-assembled for your convenience. Due to packaging restrictions, some assembly of Models SHC-2100, SHC-2400 and HCA-2400 is required.

After opening the carton, check for damage. Immediately notify your retailer or ECHO Dealer of damaged or missing parts. Use the contents list to check for missing parts.

CONTENTS LIST

	<u>MODEL</u>
_____ 1 - Shaft Hedge Clipper Assembly	ALL
_____ 1 - Shaft Assembly	HCA-2400
_____ 1 - Power Head Assembly	SHC-2400/HCA-2400
_____ 1 - Cutting Attachment Assembly	HCA-2400
_____ 1 - Gear Housing Assembly	
_____ 1 - Operator's Manual	ALL
_____ 1 - Hedge Clipper Safety Manual	ALL
_____ 1 - Warranty Statement	ALL
_____ 1 - Warranty Registration Card	ALL
_____ 1 - 2-Stroke Oil Sample, 2.6 oz.	ALL
_____ 1 - T-Wrench	ALL
_____ 1 - 3mm Hex wrench	SHC-2100/2400/HCA-2400
_____ 1 - 4mm Hex Wrench	SHC-2100/2400/HCA-2400
_____ 1 - 8mm/10mm Wrench	SHC-2400
_____ 1 - Shoulder Strap Assembly	HCA-2400
_____ 1 - Front Handle Assembly	HCA-2400
_____ 1 - Safety Glasses	ALL

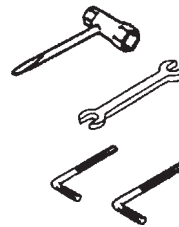
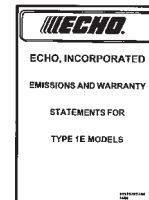
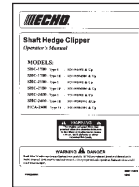

EMISSION CONTROL

The emission control system for this engine is EM (Engine Modification).

IMPORTANT ENGINE INFORMATION
ENGINE FAMILY : TEH021UB24RA
DISPLACEMENT : 23.6 cc
THIS ENGINE MEETS U.S. EPA PHI AND 1995 - 1999
CALIFORNIA EMISSION REGULATIONS FOR ULGE
ENGINES. REFER TO OWNER'S MANUAL FOR
MAINTENANCE SPECIFICATIONS AND ADJUST-
MENTS.



KIORTZ CORP.

An Emission Control Label is located on the engine. (This is an EXAMPLE ONLY, information on label varies by engine FAMILY).

12 ECHO®

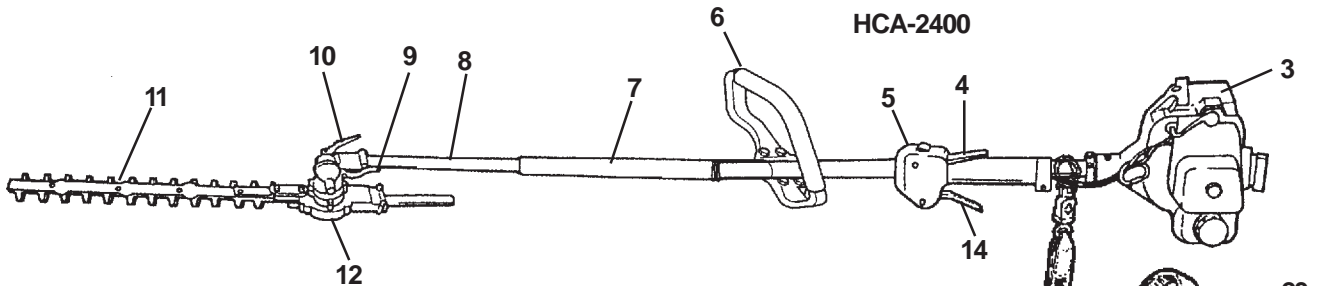
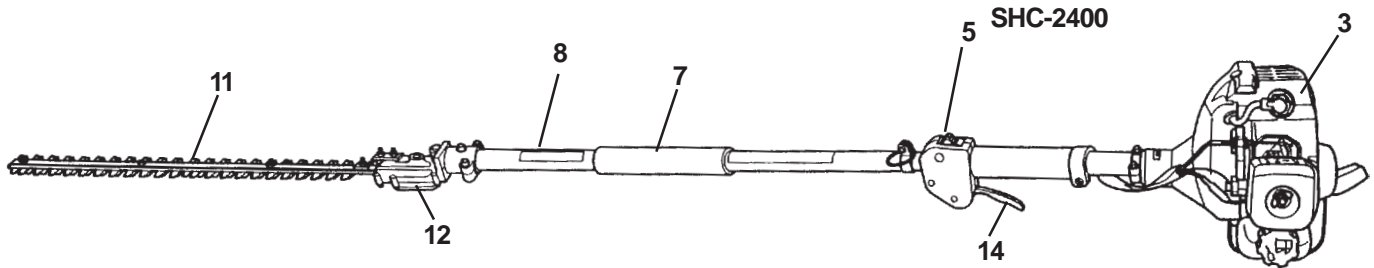
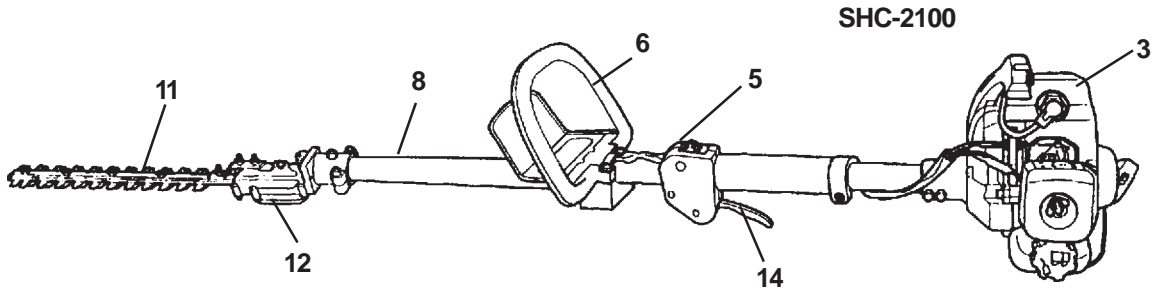
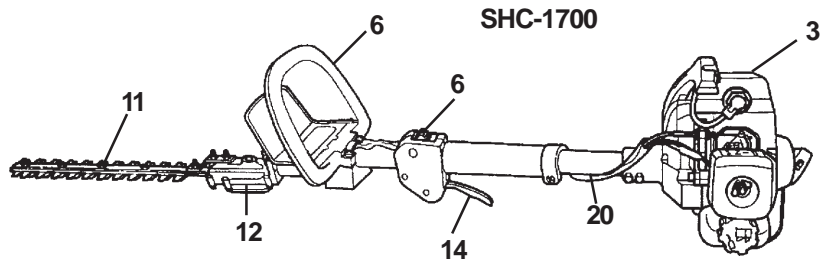
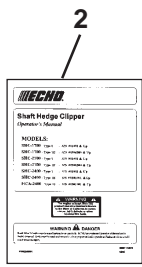

SHC-1700, 2100

SHC-2400, HCA-2400

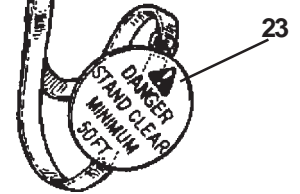
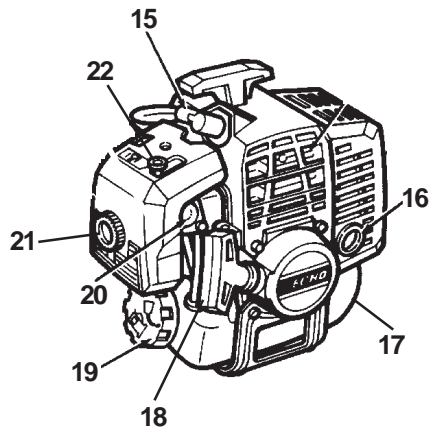
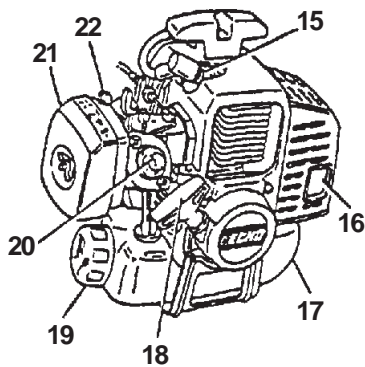

1. **SAFETY MANUAL** - Read and understand this manual before operation. Keep manual in a safe location as a reference for safe operating techniques.
2. **OPERATOR'S MANUAL** - Read and understand this manual before operation. Keep manual in a safe location for future reference, i.e., operation, maintenance, storage and specifications.
3. **POWER HEAD** - Factory Assembled. Includes the Engine, Clutch, Fuel System, Ignition System and Recoil Starter.
4. **IDLE START INTERLOCK** - HCA Model. This lever must be held during starting and idle operation when throttle trigger is disengaged, otherwise engine will stop. The engine does not stop when trigger interlock lever is released and throttle trigger is engaged during throttle operation. Operation of the throttle trigger is prevented unless interlock lever is engaged.
5. **STOP SWITCH** - mounted on top of the Throttle Trigger Housing. Move switch FORWARD to RUN, BACK to STOP.
6. **FRONT HAND (LEFT) HANDLE (SHC-1700, SHC-2100)** - Adjustable for proper cutting attitude and operator comfort.
7. **GRIP, FRONT (LEFT) HAND, (SHC-2400, HCA-2400)** - Cushioned grip for Left Hand.
8. **DRIVE SHAFT ASSEMBLY** - Contains the Flexible Drive Cable.
9. **BLADE ANGLE INDEXING LEVER (HCA-2400)** - Spring loaded lever that engages with a notch every 15 degrees, from the straight (in line with drive shaft) position to right angle with the drive shaft.
10. **BLADE ANGLE LOCKING LEVER (HCA-2400)** - The lever DOES NOT secure gear box angle setting. This lever MUST be placed in the engaged (tight) position to remove internal gear play before operating the hedge clipper.
11. **BLADES** - Double reciprocating blades mounted to a blade support bar. Double sided blades, are capable of cutting on either side of the blade.
12. **GEAR HOUSING ASSEMBLY (SHC-1700, 2100, 2400)** - Gear housing assembly fixed straight extension.
13. **GEAR HOUSING ASSEMBLY (HCA-2400)** - Gear housing assembly cutting angle is adjustable through a 90° arc.
14. **THROTTLE TRIGGER** - Spring loaded to return to idle when released. During acceleration, depress gradually for best operating technique.
15. **SPARK PLUG** - Provides spark to ignite fuel mixture.
16. **MUFFLER/SPARK ARRESTOR** - The muffler controls the exhaust noise while the spark arrestor prevents hot, glowing particles of carbon from leaving the muffler where they could possibly start a fire.
17. **FUEL TANK** - Contains fuel and fuel filter.
18. **RECOIL STARTER HANDLE** - Pull handle slowly until starter engages, then quickly and firmly. DO NOT pull rope all the way out or allow the handle to snap back, damage to the recoil starter will occur.
19. **FUEL TANK CAP** - Covers and seals fuel tank opening.
20. **PURGE BULB** - Before starting and after filling the fuel tank, pump purge bulb 3-4 times or until a steady stream of fresh fuel is visible through the "clear" fuel return line.
21. **AIR CLEANER** - Contains replaceable filter element.
22. **CHOKE CONTROL** - The choke control lever is located on the top of the air filter case. Move the lever to "COLD START" to close the choke and back to "RUN" to open the choke.
23. **SHOULDER HARNESS** - Standard - HCA-2400. An adjustable strap that suspends the unit from the operator.
24. **HEDGE CLIPPER SAFETY VIDEO** - P/N 99922202800 (Not included with unit and English version only) is available for your review and purchase at a cost of \$5.00 from ECHO, INC. or any authorized ECHO dealer. The video overviews safety precautions and proper operating techniques provided in detail in the Safety Manual, and is supplemental to the Safety Manual. Read and understand the Safety Manual for complete information on safe operation.

SPECIFICATIONS

MODEL	SHC-1700 1/E	SHC-2100 1/E	SHC-2400 1/E	HCA-2400 1E
Length	1395 mm (54.9 in.)	1816 mm (71.5 in.)	2190 mm (86.3 in.)	2034 mm (80.1 in.)
Width	216 mm (8.5 in.)	216 mm (8.5 in.)	216 mm (8.5 in.)	216 mm (8.5 in.)
Height	235 mm (9.3 in.)	235 mm (9.3 in.)	229 mm (9.0 in.)	229 mm (9.0 in.)
Weight (dry) *	5.6 kg (12.4 lb.)	5.6 kg (12.3 lb.)	5.7 kg (12.6 lb.)	6.2 kg (12.6 lb.)
Engine Type	Air cooled, two-stroke, single cylinder gasoline engine			
Bore	32.2 mm (1.27 in.)	32.2 mm (1.27 in.)	34.0 mm (1.34 in.)	34.0 mm (1.34 in.)
Stroke	26.0 mm (1.04 in.)			
Displacement	21.2 cc (1.29 cu. in.)	21.2 cc (1.29 cu. in.)	23.6 cc (1.44 cu. in.)	23.6 cc (1.44 cu. in.)
Exhaust	Spark Arrestor Muffler			
Carburetor	Diaphragm w/primer			
Ignition System	Flywheel Magneto, CDI (capacitor discharge ignition) with ESG			
Spark Plug	NGK BPM-7A (Gap 0.65 mm (0.026 in.))		NGK BPM-7Y (Gap 0.65 mm (0.026 in.))	
Fuel	Mixed (Gasoline and Two-stroke Oil)			
Fuel/Oil Ratio	50:1 ECHO High Performance, two-stroke air cooled engine oil			
Gasoline	89 Octane unleaded. DO NOT use fuel containing methyl alcohol, more than 10% ethyl alcohol or 15% MTBE.			
Oil	50:1 ECHO High Performance, two-stroke air cooled engine oil			
Fuel Tank Capacity	0.5 lit. (17.0 US fl. oz.)			
Recoil Starter System	Automatic Recoil Starter			
Clutch	Centrifugal Type			
Gear Case Ratio	6.36:1 Reduction			3.5:1 Reduction
Gear Case Lubrication	All purpose lithium based grease every 50 hours of use			
Cutter	Double Reciprocating Blade - Double Edge			
Length	420 mm (16.5 in.)	524 mm (20.5 in.)	524 mm (20.5 in.)	450 mm (17.7 in.)
Pitch	35 mm (1.4 in.)			
Idle Speed	2800 - 3200 RPM			
Wide Open Throttle Speed	8000 - 10000 RPM			

ASSEMBLY (HCA-2400, SHC-2100, 2400)

SHC-1700 is Factory Assembled in the box.

GEAR HOUSING ASSEMBLY/DRIVE SHAFT (SHC-2400, HCA-2400)

Tools Required: 8mm x 10mm Open End Wrench, 4 mm Hex Wrench

Parts Required: Power Head/Drive Shaft Assembly and Gear Housing Assembly.

NOTE

Hedge Clipper Blades are very sharp. Wear gloves to protect hands.

1. Slide the Gear Housing Assembly on the Drive Shaft. Be certain the Flex Drive Shaft engages the hole in Driver Gear.
2. Align the locating screw (A) with the locating hole (B) in the Drive Shaft Housing, tighten screw (A) and clamping screws (C).

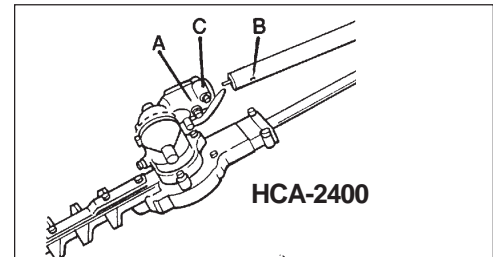
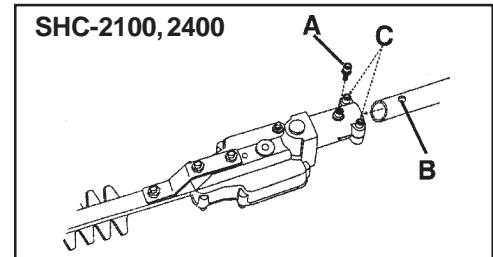

POWER HEAD/DRIVE SHAFT (SHC-2400, HCA-2400 Only)

1. Stand engine upright on a level surface.
2. Loosen the two bolts at engine drive shaft end.
3. Carefully fit drive shaft assembly to engine, making sure that inner drive shaft engages into clutch mount.

NOTE

The arrow on the drive shaft housing must be in contact with the engine (arrow Δ on drive shaft indicates line).

4. Rotate the drive shaft housing until arrows are centered with engine bearing housing.
5. Tighten bolts (A).

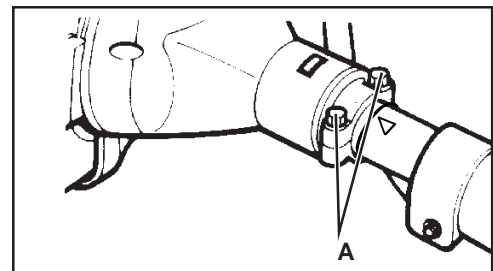

THROTTLE LINKAGE INSTALLATION

(SHC-2400, HCA-2400)

NOTE

The engine is delivered separated from shaft tube. The throttle linkage and stop switch wires are attached to the rear handle.

1. Close choke and remove air filter cover.
2. Loosen outer 10mm nut (A) on throttle linkage.
3. Insert throttle linkage in fan cover slot (B).
4. Finger tighten nut (A) and attach the inner linkage to the swivel (C) on the carburetor throttle plate.

NOTE

It is important that the head of the throttle linkage fits inside the slot well of the swivel (C).

5. Tighten the 10mm linkage nuts (A).
6. Check throttle for freedom of movement and make sure it returns to idle position. If the throttle cable does not allow the carburetor throttle plate (D) to return to idle against idle screw (E), loosen cable nuts; turn throttle cable nut (A) counter clockwise until throttle plate (D) rests against idle screw (E). Hold cable nut (A) from turning and tighten other cable nut.
6. Connect ground wire terminal under screw on fan housing.
7. Connect stop switch wire to stop wire on engine.
8. Install air filter and cover.

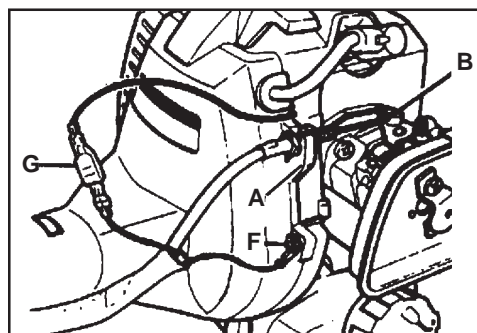
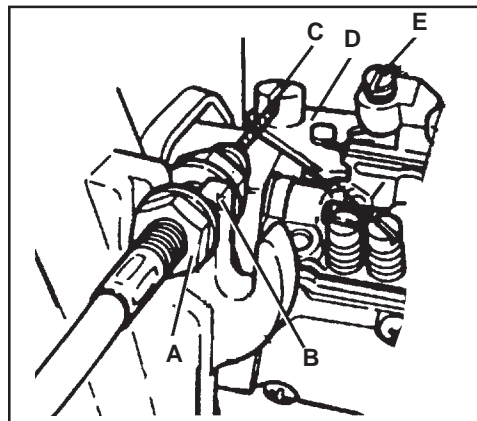

PRE-OPERATION

FUEL

Fuel Requirements

Gasoline - Use 89 Octane [$\frac{R+M}{2}$] (mid-grade or higher) gasoline or gasohol known to be good quality. Gasohol may contain up to 10% Ethyl (grain) alcohol or 15% MTBE (methyl tertiary-butyl ether). Gasohol containing methanol (wood alcohol) is **NOT** approved.

Two Stroke Oil - A two-stroke engine oil meeting ISO-L-EGD Standard (ISO/CD 13738), must be used. Echo brand Premium 50:1 oil meets this standard. Engine problems due to inadequate lubrication caused by failure to use an ISO-L-EGD approved oil, such as Echo Premium 50:1 Two-stroke Oil, will void the two-stroke engine warranty. (Emission related parts only are covered for two years, regardless of two-stroke oil used, per the statement listed in the EPA Phase I/California Emission Defect Warranty Explanation.)

Mixing - Follow directions on the oil container.

Handling Fuel

WARNING DANGER

Fuel is **VERY** flammable. Use extreme care when mixing, storing or handling or serious personal injury may result.

- Use an approved fuel container.
- DO NOT smoke near fuel.
- DO NOT allow flames or sparks near fuel.
- Fuel tanks/cans may be under pressure. Always loosen fuel caps slowly allowing pressure to equalize.
- NEVER refuel a unit when the engine is HOT!
- NEVER refuel a unit with the engine running.
- DO NOT fill fuel tanks indoors. ALWAYS fill fuel tanks outdoors over bare ground.
- Securely tighten fuel cap after refueling.
- Inspect for fuel leakage. If fuel leak is found, do not start or operate unit until leak is repaired.

After Refueling;

- Wipe any spilled fuel from the unit.
- Move at least 3M (10 ft.) from refueling location before starting.

After Use;

- DO NOT store a unit with fuel in its tank. Leaks can occur. Return unused fuel to an approved fuel storage container.

Storage

Fuel storage laws vary by locality. Contact your local government for the laws affecting your area. As a precaution, store fuel in an approved, air tight container. Store in a well ventilated, unoccupied building, away from sparks and flames. Do not store fuel longer than 30 days.

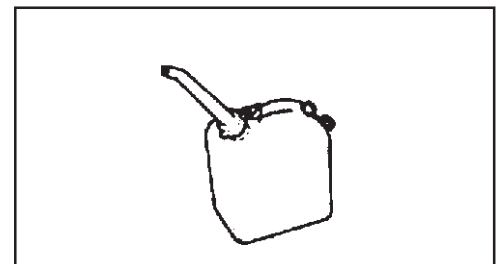
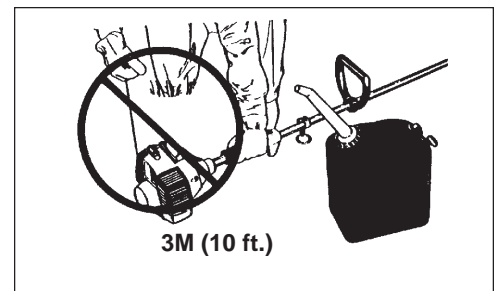
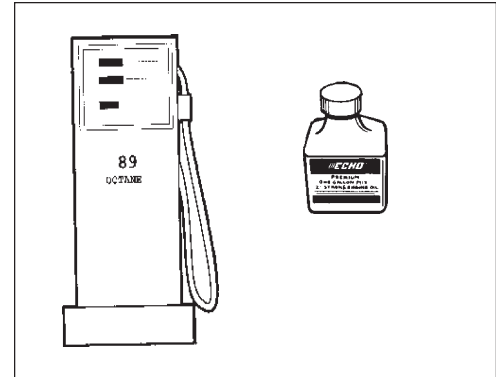

IMPORTANT

Stored fuel ages. Do not mix more fuel than you expect to use in thirty (30) days, ninety (90) days when a fuel stabilizer is added.

IMPORTANT

Stored two-stroke fuel may separate. ALWAYS shake fuel container thoroughly before each use.

S	M	T	W	T	F	S
1	2	3	4	5	6	7
8	9	10	11	12	13	14
15	16	17	18	19	20	21
22	23	24	25	26	27	28
29	30	31				

EQUIPMENT CHECK

Before operation a complete check of the unit must be performed;

- Check unit for loose/missing nuts, bolts and screws. Tighten and/or replace as needed.
- Inspect fuel lines, tank and area around carburetor for fuel leaks. DO NOT operate unit if leaks are found.
- Inspect hand guard for damage. Replace if damaged or missing.
- Check that the blade assembly is firmly attached and in safe operating condition. Dull, loose or damaged blades should not be used.
- Tighten the Blade angle adjustment lever before operating the HCA-2400.
- Check that front (loop) handle and shoulder strap/ or shoulder/waist harness are adjusted for safe, comfortable operation.

IMPORTANT

Always store and transport Shaft Hedge Clipper in a stable, horizontal position. Support gear case and cutting blades to prevent excessive flexing, which may cause damage to the cutting attachment.

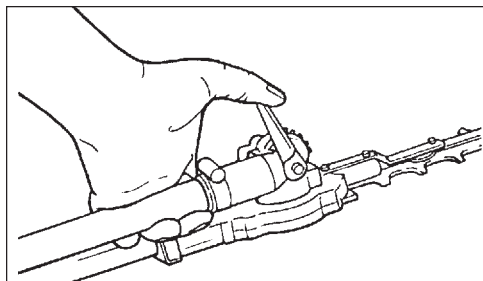
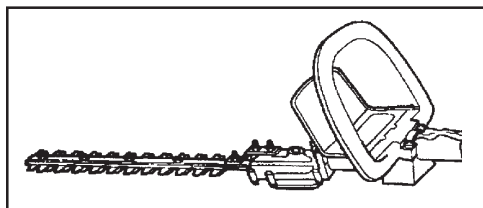
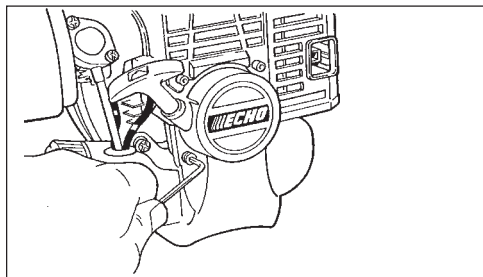

DETERMINE OPERATION AREA

WARNING DANGER

Inspect starting area for hazards such as rocks, glass, debris etc. which could be contacted by the cutting blades when starting. Keep helpers and bystanders at least 15 M (50 ft.) from starting area, otherwise serious personal injury may result.

- Review the area to be trimmed. Look for hazards that could contribute to unsafe conditions.
- Spectators and fellow workers must be warned, and children and animals prevented from coming nearer than 15 M (50 ft.) while the trimmer is in use.

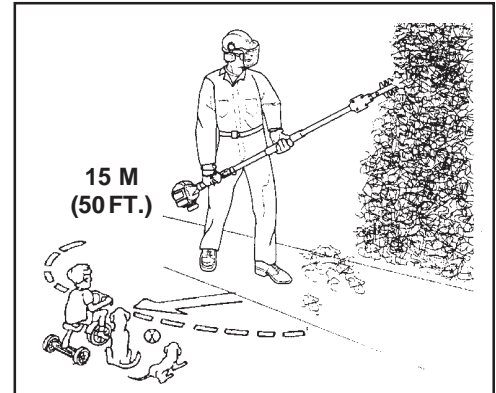

OPERATION

- Provide all operators of this equipment with the operator's manual and instructions for safe operation.
- Before starting the unit, equip yourself and any other person working within the 15 M (50 ft.) Safety Zone with the required Protective Equipment and clothing.
- Check that front (loop) handle and shoulder strap/ or shoulder/ waist harness are adjusted for safe, comfortable operation.

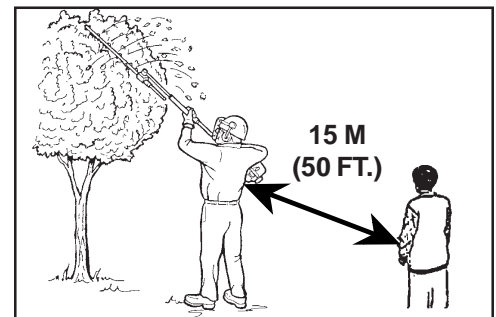
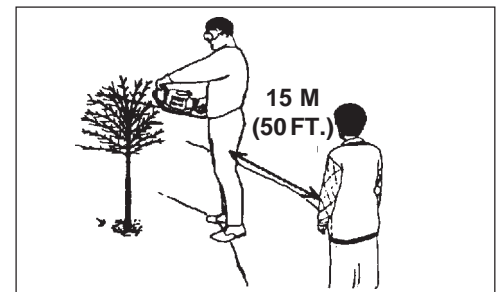

- During operation, the complete unit, especially the gear box, drive shaft housing and power head muffler area may become very hot, too hot to touch. Avoid contact during and immediately after operation.

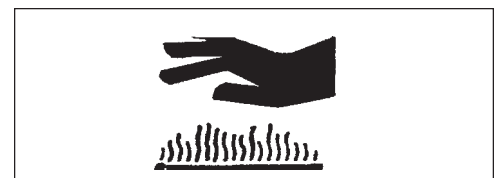

- Never adjust blade angle of HCA while standing
- Only adjust cutting angle with HCA resting flat on the ground, with the engine stop switch in the "STOP" position.
- Adjust cutting angle by moving locking lever (A) up. Depress blade indexing lever (B) and change blade angle with rear cutter assembly handle. Release indexing lever into notch. Move locking lever down to completely engage internal gears.



IMPORTANT

Locking lever (A) does not secure gear box angle setting. Moving lever in the down position reduces internal play in the gear box. Do not over tighten castle nut (C) to insure gear box angle setting tightness because damage to internal gears will occur. If the lever is loose or very tight, adjust nut (C) for snug 90° movement.

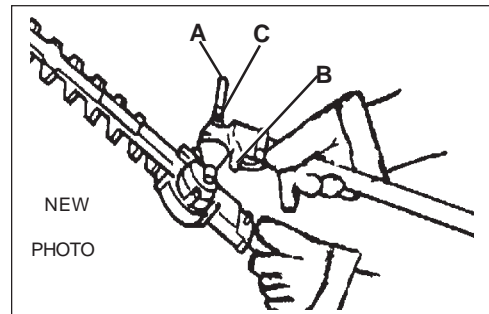

STARTING COLD ENGINE

WARNING DANGER

Blades should not move at idle. If blades move, readjust carburetor according to Carburetor Adjustment instructions in the manual or see your ECHO dealer, otherwise serious personal injury may result.

1. *Stop Switch* - Start/Run.
Move Stop Switch button away from the STOP position.
2. *Close Choke* - Cold Start.
Move choke (B) to "Cold Start" position.
3. *Primer* - Pump Bulb.
Pump primer bulb (C) 10 times. Fuel will be visible and flow freely in the "Clear" fuel return line.

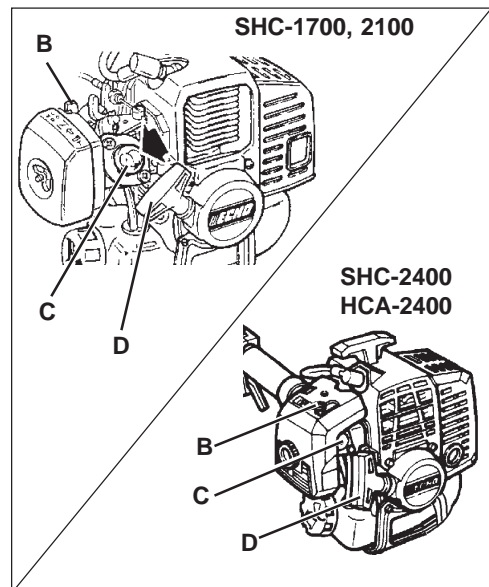
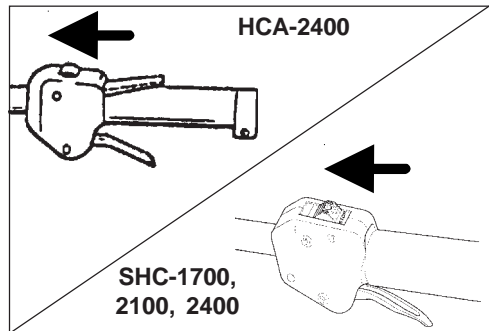

WARNING DANGER

Inspect starting area for hazards such as rocks, glass, debris etc. which could be contacted by the cutting blades when starting. Keep helpers and bystanders at least 15 M (50 ft.) from starting area, otherwise serious personal injury may result.

4A. *Starting* (SHC-1700, 2100, 2400)

Lay the trimmer on a flat, clear area. Firmly grasp throttle grip with left hand and fully depress throttle trigger to wide open position. Rapidly pull starter handle/rope (D) until engine fires (or maximum five (5) pulls.

4B. *Starting* (HCA-2400)

Lay the trimmer on a flat, clear area. With left hand, firmly grasp and hold Ignition/Idle Interlock lever and throttle trigger in wide open position. Rapidly pull starter handle/rope (D) until engine fires (or maximum five (5) pulls.

NOTE

HCA-2400 "Ignition/Idle Interlock" must be held tight against the grip or engine will stop at idle.

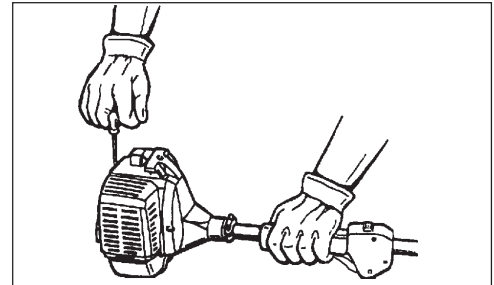

5. After engine fires or five (5) pulls, move choke lever back to "RUN" position. Hold throttle trigger fully depressed and pull starter handle/rope until engine starts and runs. Release throttle trigger and allow unit to warm up at idle for several minutes.

NOTE

If engine does not start with choke in "RUN" position after 5 pulls, repeat instructions.

6. After engine warm up, gradually depress throttle trigger to increase engine RPM to operating speed.

STARTING WARM ENGINE

The starting procedure is the same as Cold Start except DO NOT close the choke.

NOTE

If engine does not start after 5 pulls, use Cold Start Procedure.

WARNING DANGER

Blades should not move at idle. If blades move, readjust carburetor according to Carburetor Adjustment instructions in the manual or see your ECHO dealer, otherwise serious personal injury may result.

1. *Stop Switch -Start/Run.*
Move Stop Switch button away from the STOP position.

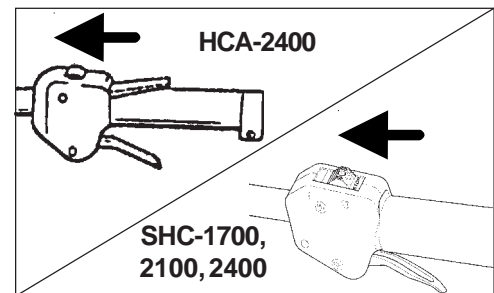

2. *Primer - Pump Bulb.*
Pump primer bulb until fuel is visible in the "Clear" fuel return line.

- 3A. *Starting - (SCH-1700, 2100, 2400)*
Lay trimmer on a flat, clear area and pull starter handle/rope (D) until engine fires.

- 3B. *Starting (HCA-2400)*
Lay the hedge clipper on a flat, clear area. With left hand, firmly grasp and hold the "Ignition/Idle Interlock" lever and throttle trigger in wide open position. Rapidly pull starter handle/rope (D) until engine fires.

NOTE

HCA-2400 "Ignition/Idle Interlock" must be held tight against the grip or the engine will stop at idle.

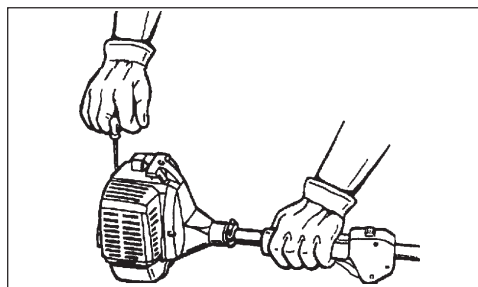
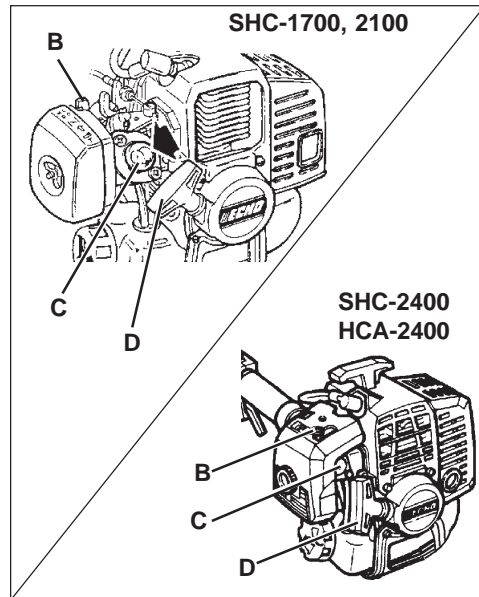

STOPPING ENGINE (SHC UNITS)

1. *Release Throttle.* Allow engine to idle down and blades stop moving with throttle trigger disengaged.
2. *Stop Switch - STOP.* Move ignition switch button backward to STOP position.

WARNING  **DANGER**

If engine does not stop when stop switch is moved to STOP position, close choke - COLD START position - to stall engine. Have your ECHO dealer repair stop switch before using hedge clipper again or serious personal injury may result.

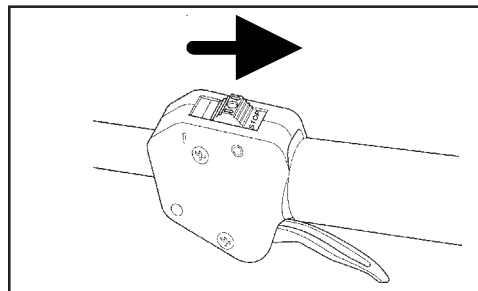

STOPPING ENGINE (HCA-2400)

1. *Release Throttle.* Allow engine to idle down and blades stop moving with throttle trigger disengaged.
2. *Release "Ignition/Idle Interlock -* Move "Stop Switch" to STOP position.

WARNING DANGER

The engine does not stop when idle start lever is released and throttle trigger is engaged. Release throttle trigger and allow engine to idle down and blades stop moving before releasing idle start interlock lever, otherwise serious personal injury may result.

WARNING DANGER

If engine does not stop during step 2, close choke - COLD START position - to stall engine. Have your ECHO dealer repair Stop Switch before using hedge clipper again or serious personal injury may result.

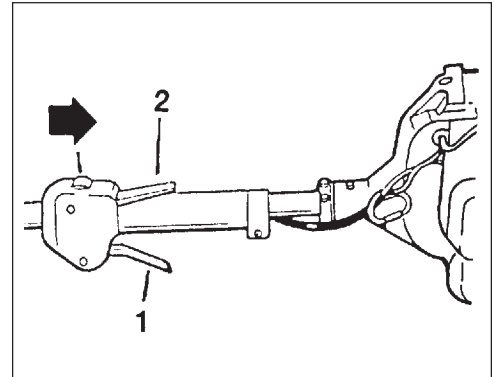

MAINTENANCE

Your ECHO product is designed to provide many hours of trouble free service. Regular scheduled maintenance will help achieve that goal. If you are unsure or are not equipped with the necessary tools, you may want to take your unit to an ECHO Service Dealer for maintenance. To help you decide whether you want to DO-IT-YOURSELF or have the ECHO Dealer do it, each maintenance task has been graded. If the task is not listed, see your ECHO Dealer for repairs.

SKILL LEVEL

- Level 1**= Easy to do. Most required tools come with unit.
- Level 2**= Moderate difficulty. Some specialized tools may be required.
- Level 3**= Experience required. Specialized tools are required.

ECHO offers **REPOWER™** Maintenance Kits and Parts to make your maintenance job easier. Just below each task heading are listed the various part numbers required for that task. See your ECHO dealer for these parts.

MAINTENANCE INTERVALS

Component/System	Maintenance Procedure	Before Use	Every Refuel	Daily or Every 4 Hours	3 Months or 100 Hours	6 Months or 300 Hours	Yearly or 600 Hours
Air Filter	Clean / Replace	I		I	R*		
Fuel Strainer	Clean/Replace				I		
Fuel Line	Inspect				I		
Carburetor	Inspect/Rebuild/Replace					I	R (1)
Choke System	Inspect/Clean/Replace		I				
Cooling System	Inspect/Clean	I		I			
Muffler Spark Arrestor	Inspect/Clean				I		
Drive Shaft	Grease				I**		
Gear Housing	Grease				I**		
Recoil Starter Rope	Inspect/Clean	I					
Fuel Leaks	Inspect/Replace	I					
Spark Plug	Clean / Replace				I	R	
Ignition System	Clean/Replace	No Maintenance required for coil and flywheel					
Screws/Nuts/Bolts	Inspect/Tighten/Replace	I					

I = Inspect / R = Replace

IMPORTANT

Time intervals shown are maximum. Actual use and your experience will determine the frequency of required maintenance.

(1) Replacement will be required for commercial use after 600 hours. For Consumer use, cleaning every 6 months is required. Cleaning includes Rebuild Kits.

**** Commercial - grease weekly or ever 25 hours of use. Consumer - grease every 25 hours of use.**

AIR FILTER

Level 1.

Tools required: Cleaning brush, 1" or 2" medium bristle paint brush.

Parts required: (SHC-1700/2100)90008REPOWER™ AIR & FUELFILTERKIT.
(SHC-2400/HCA-2400)90030REPOWER™ AIR & FUELFILTERKIT.

1. Close choke (Cold Start Position). This prevents dirt from entering the carburetor throat when the air filter is removed. Brush accumulated dirt from the air cleaner area.
2. Remove the air cleaner cover. Clean and inspect the element for damage. If element is fuel soaked and very dirty, replace.
3. If element can be cleaned and reused, be certain it:
 - properly fits the cavity in the air cleaner cover.
 - is installed with the original side out.

NOTE

Carburetor adjustment may be needed after air filter cleaning/replacement. See Carburetor Adjustment Section.

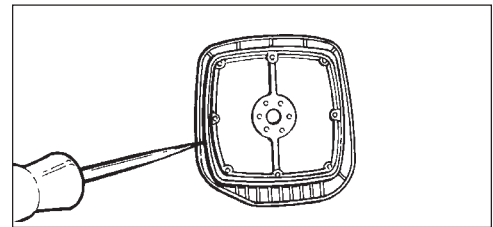
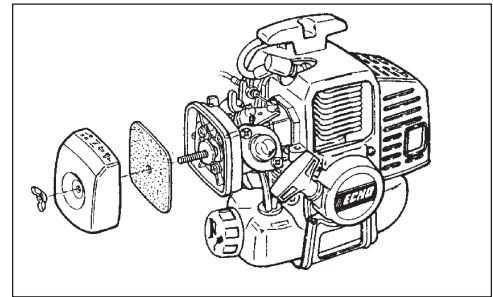
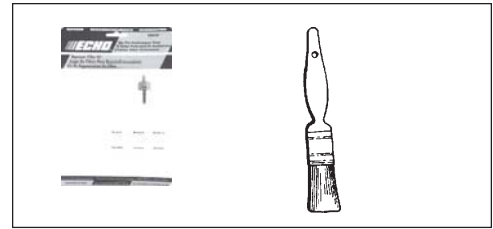

FUEL FILTER

Level 1.

Tools required: Fuel line hook. 8"-10" (203-254 mm) length of wire with one end bent into a hook. Clean rag, funnel, and an approved fuel container.

Parts Required: (SHC-1700/2100)90008REPOWER AIR & FUELFILTERKIT.
(SHC-2400/HCA-2400)90030REPOWER AIR & FUELFILTERKIT.

WARNING DANGER

Fuel is **VERY** flammable. Use extreme care when mixing, storing or handling or serious personal injury may result.

1. Use a clean rag to remove loose dirt from around fuel cap and empty fuel tank.
2. Use the "fuel line hook" to pull the fuel line and filter from the tank.
3. Remove the filter from the line and install the new filter.

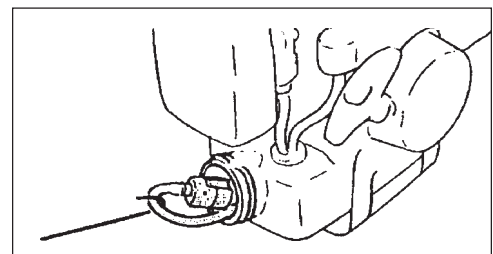
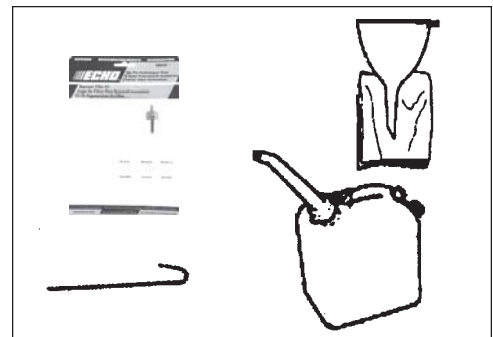

SPARK PLUG

Level 2.

Tools Required: T-Wrench. Feeler gauge. Preferably a wire gauge. Brush.

Parts Required: Spark Plug, (SHC-1700/2100)NGK BPM-7A
P/N 15901010630
(SHC-2400, HCA-2400)NGK BPM-7Y
P/N 99944500071

1. Remove spark plug and check for fouling, worn and rounded center electrode.
2. Clean the plug or replace with a new one. DO NOT sand blast to clean. Remaining sand will damage engine.
3. Adjust spark plug gap by bending outer electrode.
4. Tighten spark plug to 145-155 kg/cm (125-135 in. lb.).

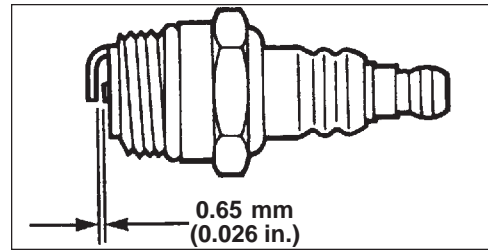
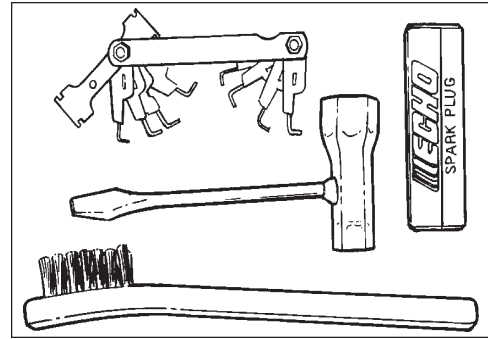

COOLING SYSTEM CLEANING

Level 3.

Tools required: Cross Head Screwdriver, 3 mm Hex wrench, 4 mm Hex wrench, Pointed Wood Stick, Cleaning Brush, 1"-2" medium bristle paint brush.

Parts Required: None.

IMPORTANT

To maintain proper engine operating temperatures, cooling air must pass freely through the cylinder fin area. This flow of air carries combustion heat away from the engine.

Overheating and engine seizure can occur when:

- Air intakes are blocked, preventing cooling air from reaching the cylinder.
- Dust and grass build up on the outside of the cylinder. This build up insulates the engine and prevents the heat from leaving.

Removal of cooling passage blockages or cleaning of cooling fins is considered "Normal Maintenance". Any failure attributed to lack of maintenance is not warranted.

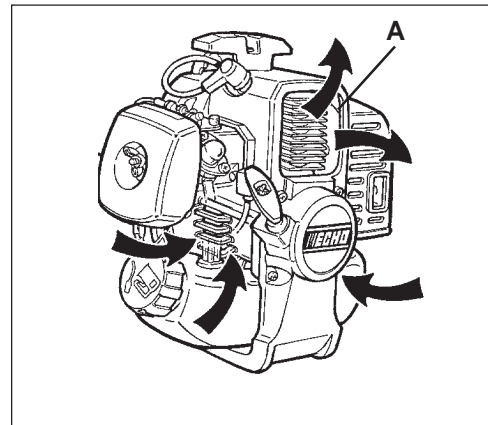
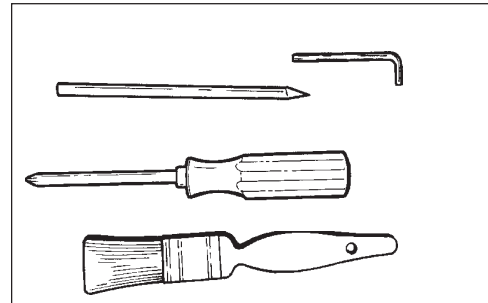

1. Remove spark plug lead from the spark plug and throttle linkage end from the carburetor swivel.
2. Remove the four screws that retain the engine cover. Two at the top of the starter, two on either side of the front. Lift the cover from the engine and lay to the front of the hedge clipper.

NOTE

The throttle linkage remains assembled to the engine cover and the spark plug lead and grommet remain installed.

3. Use the wooden stick or brush to remove dirt from the cylinder fins.
4. Remove grass and leaves from the grid between the recoil starter and fuel tank.
5. Assemble components in reverse order.

NOTE

When installing the engine cover, be certain the tab of the metal deflector shield is in the slot of the cover.

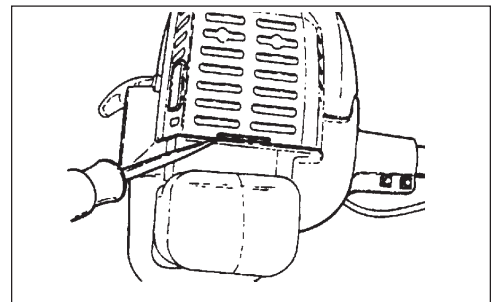
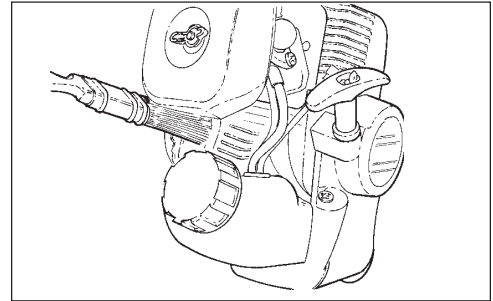
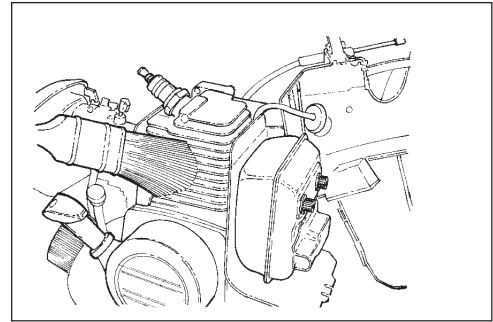

EXHAUST SYSTEM

Spark Arrestor Screen

Level 2.

Tools Required: Cross Head Screwdriver. Soft metal brush.

Parts Required: Screen P/N 14586240630, Gasket Lid P/N 14586642031

1. Remove engine cover (A). See "Cleaning Cooling System" pages 26 and 27 for step by step instructions.
2. Place piston at Top Dead Center (TDC) to prevent carbon/dirt from entering cylinder.
3. Remove spark arrestor screen cover (B), screen holder (C), gasket (D) and screen (E) from muffler body.
4. Clean carbon deposits from screen and muffler components.
5. Replace screen if it is cracked, plugged or has holes burned through.
6. Assemble components in reverse order.

NOTE

When installing the engine cover, be certain the tab of the metal deflector shield is in the slot of the cover.

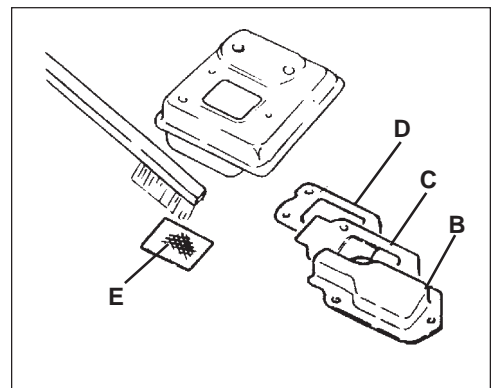
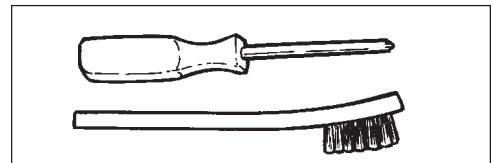

CARBURETOR ADJUSTMENT

Emission Models (with limiter caps)

Level 2.

Tools required: Screwdriver, Tachometer (ECHOP/N99051130017).

Parts required: None.

NOTE

Every unit is run at the factory and the carburetor is set in compliance with EPA Phase 1 and California Emission Regulations. In addition, the carburetor is equipped with HI and LO needle adjustment limiters that prevent settings outside acceptable limits.

1. Before adjusting the carburetor, clean or replace the air filter and spark arrester screen.
2. Start engine and run for several minutes to reach operating temperature.
3. Stop engine. Turn HI speed needle (A) CCW (counter clockwise) to stop. Turn LO speed needle (B) midway between full CCW and CW (clockwise) stops.
4. Idle Speed Adjustment.
 - Start engine and turn "idle" speed adjustment screw (C) CW until the blades begin to move, then turn the screw CCW until blades stop moving. Turn screw CCW an additional 1/4 turn.
5. Accelerate to full throttle for 2-3 seconds to clear excess fuel from engine then return to idle. Accelerate to full throttle to check for smooth transition from idle to full throttle. If engine hesitates, turn LO needle (B) CCW an additional 1/8 turn and repeat acceleration. Continue adjusting until smooth acceleration results.
6. Check HI speed RPM at W.O.T. (Wide Open Throttle). HI speed RPM should be set to specifications found on page 14 "Specifications" of this manual.
7. Check idle speed and reset if necessary. If a tachometer is available, idle speed should be set to the specification found on page 14 "Specifications" of this manual.

WARNING DANGER

When carburetor adjustment is completed, blades should not move at idle, otherwise serious personal injury may result.

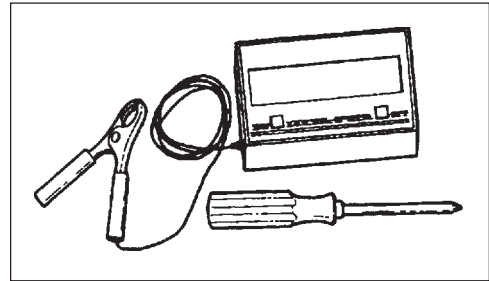

SHC-1700, 2100 TYPE 1E

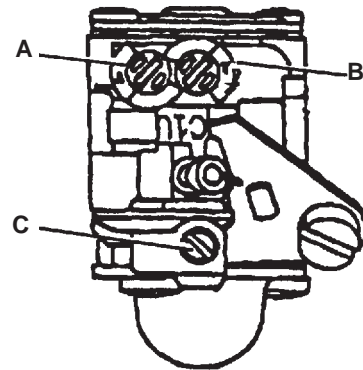

SHC-2400
TYPE 1E

HCA-2400
TYPE 1E

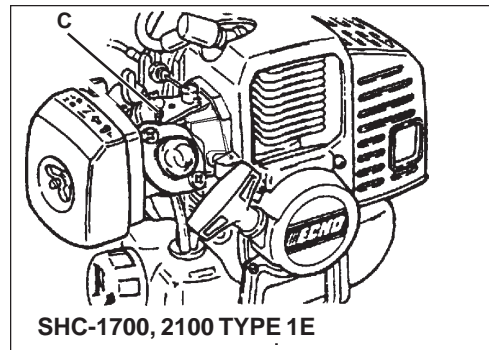
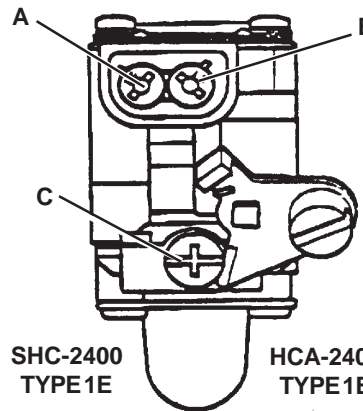

SHC-1700, 2100 TYPE 1E

CARBURETOR ADJUSTMENT

Non Emission Models (without limiter caps)

Tools required: Screwdriver, Tachometer (ECHOP/N99051130017).

NOTE

If carburetor has limiter caps follow "Carburetor Adjustment" procedures for Emission models on previous page.

Idle Speed Adjustment

Turn "idle" speed adjustment screw (C) CW (clockwise) until blades begin to move, then turn screw out CCW (counter clockwise) until blades stop moving. Turn screw out, CCW an additional 1/4 turn.

WARNING DANGER

Blades must not move when unit is idling, otherwise serious personal injury may result.

Basic Setting

1. Stop engine and turn both LO (B) and HI (A) needles in, CW until they stop and are lightly seated.

IMPORTANT

DO NOT over tighten needles. Forcing them to tighten will damage the carburetor.

2. Turn LO needle (B) out, CCW 1-1/4 turns. Turn HI needle (A) out CCW 2-3/4 turns.

Fine Tuning

(Requires Accurate Tachometer ECHO P/N 99051130017)

1. Start engine and allow to warm to operating temperature (minimum 2 - 3 minutes) varying engine speed from idle to full throttle.
2. Always begin fine tuning with LO needle (B).
 - a. Lean drop-off - With engine idling, turn LO needle (B) slowly CW (in) to lean drop-off point. RPM will increase, then abruptly drop-off. (1) Note this position.
 - b. Rich drop-off - With engine idling, slowly turn LO needle (B) CCW (out) to rich drop-off point. RPM will increase then gradually slow and drop-off. (2) Note this position.
 - c. Final setting - Set needle at mid point between lean rich drop-off points. (3)
 - d. Turn 1/8 turn CCW (out) making mixture slightly richer. (4)
3. High speed adjustment.
Adjust HI needle (A) with tachometer to achieve the specifications found on page 14 "Specifications" of this manual.
4. Check idle speed and reset if necessary. Using a tachometer, idle speed should be set to the specification found on page 14 "Specifications" of this manual.

WARNING DANGER

When carburetor adjustment is completed blades should not move at idle, otherwise serious personal injury may result.

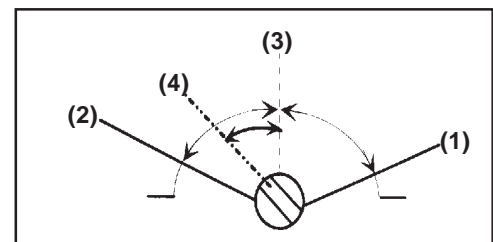
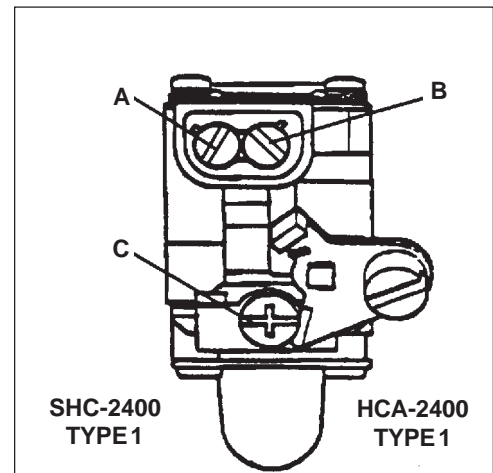
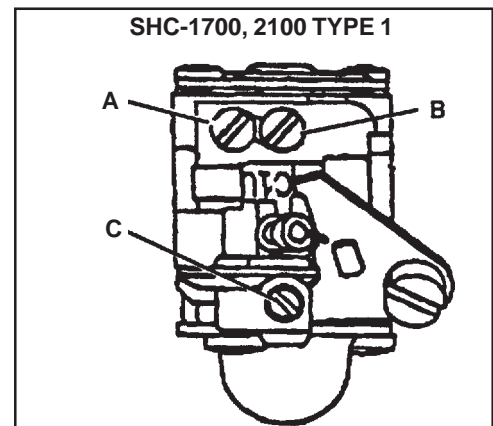

LUBRICATION

Blades

Level 1.

Tools Required: Clean Rag, Brush, Oil Can, (2) 10 mm wrenches.

Parts Required: 20W Engine Oil (lubrication), 50-50 mixture of kerosene and 20W oil (cleaning).

WARNING DANGER

Blades are very sharp. Wear gloves to protect hands, otherwise serious personal injury may result.

1. Brush loose debris from blade and coat both sides of blade with the 50-50 cleaning mixture.
2. Allow cleaning mixture to soften the remaining gummy residue then wipe it from the blade.
3. Apply clean oil to the entire length of the blade. Be certain the blade bolts are lubricated.
4. Wipe excess oil from the blade before putting the unit back in service.
5. Check blade tightness. Tighten blade bolts (A) until snug with 10 mm wrench. Loosen bolts 1/2 turn. Hold bolts (A) from turning and tighten locknuts (B) with other 10 mm wrench.

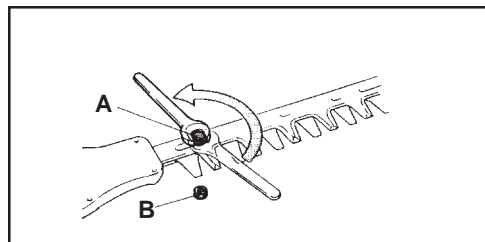
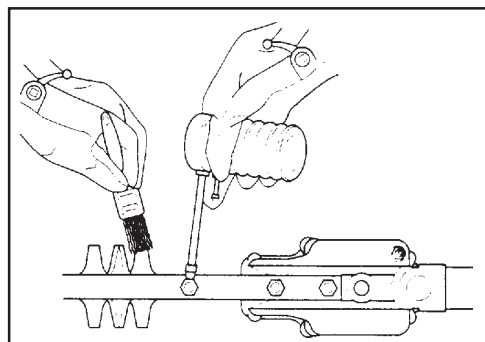
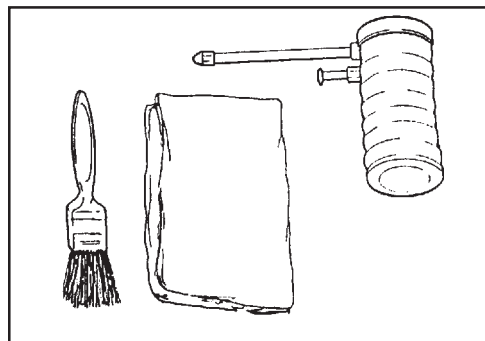

Gear Case

Tools required: Grease Gun with Lithium Grease, Rag.

Parts required: Lithium Based Grease.

1. Clean dirt from grease fittings.
2. Carefully pump grease in each fitting. **DO NOT** force grease. Too much pressure will force grease past seals and cause damage. **Apply 1-2 pumps of grease every 15-20 hours of operation.** Lubrication should be performed as follows:
 - Commercial Use - Grease weekly or every 25 hours of use.
 - Consumer Use - Grease every 25 hours of use.

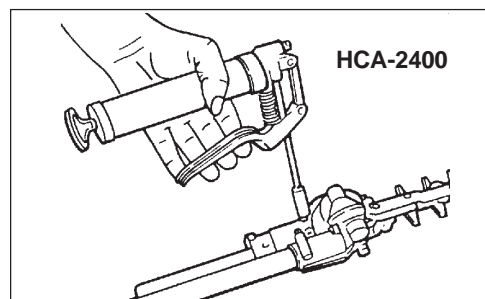
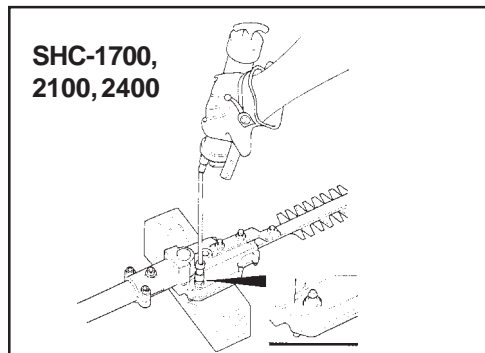

Drive Shaft Assembly

NOTE

Hedge Clipper drive shaft should be greased every 25-50 hours of operation.

Tools required: 8 mm Open End Wrench, Screwdriver, Clean Rag, Small Brush.

Parts required: Lithium Based Grease.

WARNING DANGER

Blades are very sharp. Wear gloves to protect hands, otherwise serious personal injury may result.

1. Loosen gear housing assembly locating screw (A) and mounting screws (C). Remove the gear box from the drive shaft housing.
2. Pull the drive shaft (B) from the housing, wipe clean and re-coat with a thin coating [1/2 oz. (15 ml)] of lithium based grease.
3. Slide the drive shaft back in the drive housing being careful not to get dirt on the flex shaft.
4. Install the gear housing assembly.

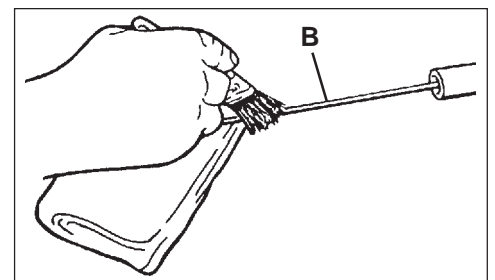
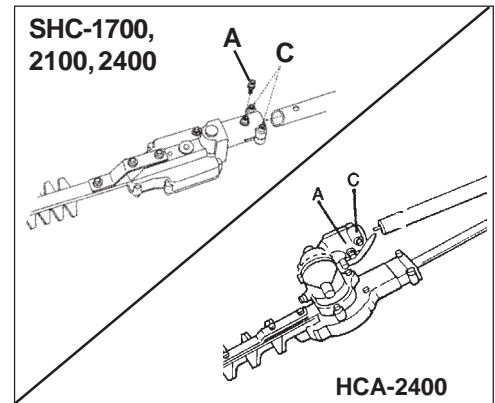
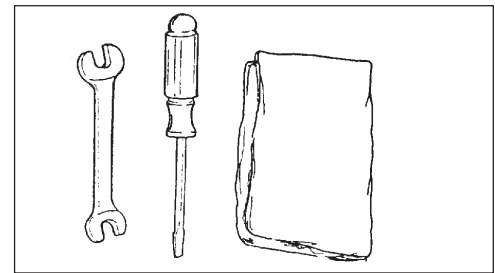

SHARPENING BLADES

Level 2.

Tools required: Flat file, Small Screwdriver

Parts required: Lithium Based Grease.

NOTE

Hedge Clipper Blades are very sharp. Wear gloves to protect hands.

1. Use screwdriver to separate upper and lower cutters equal distance apart.
2. File each edge carefully. Follow the original shape of the blade.

IMPORTANT

If a power grinder is used **DO NOT** allow blade to over heat.

3. Lubricate blades. See "Blade Lubrication Instructions", page 30 this section.

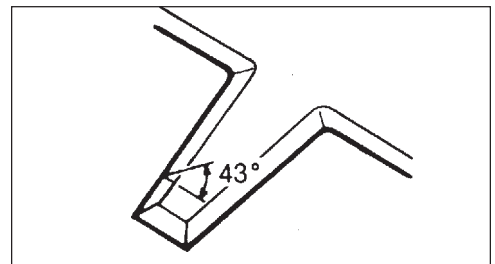
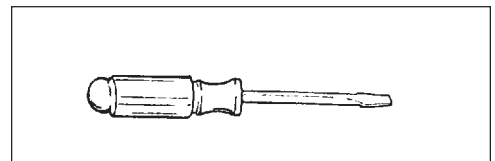

TROUBLESHOOTING

Problem			
Engine -- starts hard			
Engine -- does not start		Cause	Remedy
Engine Cranks	Fuel at carburetor	No fuel at carburetor	Fuel strainer clogged Fuel line clogged Carburetor
	↓		
	Fuel at cylinder	No fuel at cylinder	Carburetor
	↓		
		Muffler wet with fuel	Fuel Mixture is too rich
			Open choke Clean/replace air filter Adjust carburetor See your ECHO dealer
	Spark at end of plug wire	No spark at end of plug wire	Stop switch off Electrical problem Interlock switch
	↓		
	Spark at plug	No spark at plug	Spark gap incorrect Covered with carbon Fouled with fuel Spark plug defective
	↓		
Engine does not crank			Internal engine problem
			See your ECHO dealer
Engine runs	Dies or accelerates poorly		
↓	↓		
			Air filter dirty Fuel filter dirty Fuel vent plugged Spark plug Carburetor Cooling system plugged Spark arrestor screen plugged
			Clean or replace Replace Replace Clean and adjust/replace Adjust Clean Clean

WARNING DANGER

Fuel vapors are **extremely** flammable and may cause fire and/or explosion. **Never** test for ignition spark near an open spark plug opening, otherwise serious personal injury may result.

STORAGE

Long Term Storage (over 30 days)

Do not store your unit for a prolonged period of time (30 days or longer) without performing protective storage maintenance which includes the following:

1. Store unit in a dry, dust free place, out of the reach of children.

WARNING  **DANGER**

Do not store in enclosure where fuel fumes may accumulate or reach an open flame or spark or serious personal injury may result.

2. Place the stop switch in the "OFF" position.
3. Remove accumulation of grease, oil, dirt and debris from exterior of unit.
4. Perform all periodic lubrication and services that are required.
5. Tighten all the screws and nuts.
6. **Drain** the fuel tank **completely** and pull the recoil starter handle several times to remove fuel from the carburetor.
7. Remove the spark plug and pour 7 cc (1/4 oz.; 1/2 tablespoon) of fresh, clean, two-stroke engine oil into the cylinder through the spark plug hole.
 - A. Place a clean cloth over the spark plug hole.
 - B. Pull the recoil starter handle 2-3 times to distribute the oil inside the engine.
 - C. Observe the piston location through the spark plug hole. Pull the recoil starter handle slowly until the piston reaches the top of its travel and leave it there.
8. Install the spark plug (do not connect spark plug cable).

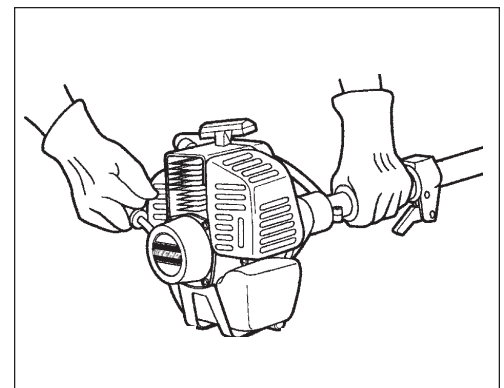
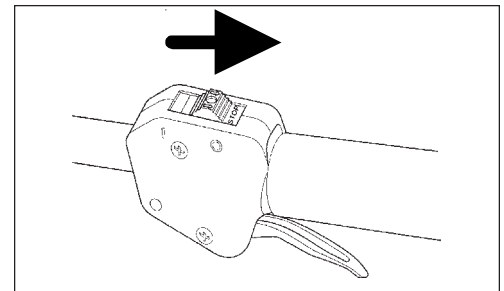

IMPORTANT

Always store and transport Shaft Hedge Clipper in a stable, horizontal position. Support gear case and cutting blades to prevent excessive flexing, which may cause damage to the cutting attachment.

NOTES

NOTES

SERVICING INFORMATION

PARTS

Genuine ECHO Parts and ECHO REPOWER™ Parts and Assemblies for your ECHO products are available only from an Authorized ECHO Dealer. When you do need to buy parts **always** have the Model Number, Type number and Serial Number of the unit with you. You can find all three numbers on the engine housing. For future reference, write them in the space provided below.

Model No. _____ Type No. _____ SN. _____

SERVICE

Service of this product during the warranty period must be performed by an Authorized ECHO Service Dealer. For the name and address of the Authorized ECHO Service Dealer nearest you, ask your retailer or call: 1-800-432-ECHO (3246). When presenting your unit for Warranty service/repairs, proof of purchase is required.

ECHO CONSUMER PRODUCT SUPPORT

If you require assistance or have questions concerning the application, operation or maintenance of this product you may call the ECHO Consumer Product Support Department at 1-800-673-1558 from 8:00 am to 5:00 pm (Central Standard Time) Monday through Friday. Before calling, please know the model and serial number of your unit to help your Consumer Product Support Representative.

WARRANTY CARD

This card is our means of registering all original owners of ECHO equipment. The card plus proof of purchase provides you the assurance that authorized warranty work will be done. It also provides a direct link between you and ECHO if we find it necessary to contact you.

ADDITIONAL OR REPLACEMENT MANUALS

Safety Manuals are available, free of charge, from your ECHO dealer or by contacting Echo Incorporated, 400 Oakwood Road, Lake Zurich, IL 60047.

Operator's and Parts Manuals are available for purchase from your ECHO dealer or directly from ECHO. [See ordering instructions below.]

ORDERING INSTRUCTIONS

To obtain a Parts Catalog or Operator's Manual send a check or money order for \$2.00 per Parts Catalog or \$1.50 per Operator's Manual made payable to ECHO, INCORPORATED. State on a sheet of paper the model number and serial number of the ECHO unit you have, part number of the manual (if known), your name and address and mail to address above.

Available Parts Catalog

SHC-1700 Type 1/1E S/N 001001 & Up	99922202849
SHC-2100 Type 1/1E S/N 001001 & Up	99922202850
SHC-2400 Type 1/1E S/N 001001 & Up	99922202851
HCA-2400 Type 1/1E S/N 001001 & Up	99922202852

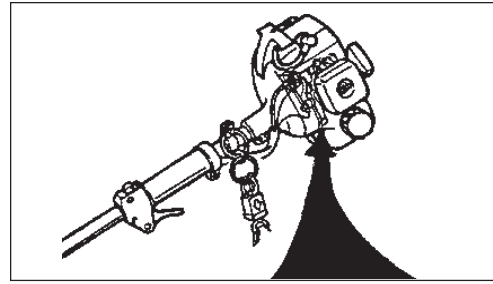

DEALER?
Call
1-800-432-ECHO

**CONSUMER PRODUCT
SUPPORT**
1-800-673-1558
8 - 5 Mon - Fri C.S.T.

WARRANTY CARD / TARJETA DE GARANTIA LIMITADA
(Only of Limited Warranty for use with Operator's Manual)
(Solo de Garantia limitada para uso con Manual del Operador)

Please Print / Por Favor Escriba Con Letra De Manita	
Customer Name / Nombre del Cliente	Model No. / No. Modelo
Name / Nombre	SN. / No. de Serie
Date / Fecha	City / Ciudad
Dealer Name / Nombre del Distribuidor	Date of Purchase / Fecha de Compra
City / Ciudad	State / Estado
Dealer Name / Nombre del Distribuidor	Model No. / No. Modelo
City / Ciudad	State / Estado
Customer Signature / Firma del Cliente	Dealer Signature / Firma del Distribuidor

TO PURCHASE A COPY OF THE ECHO SAFETY-VISOR/OPERATOR CONTACT MANUALS FOR ALL MODELS OF ECHO, CONTACT:
ECHO, INCORPORATED
ATTN: VIDEOOPER
400 OAKWOOD ROAD
LAKE ZURICH, IL 60047, U.S.A.
815.326.2222

ECHO, Incorporated
400 Oakwood Road
Lake Zurich, IL 60047
Technical Publications Orders

ECHO®

ECHO, INCORPORATED

400 OAKWOOD ROAD
LAKE ZURICH, IL 60047